

Recommended Lip Installation Angle

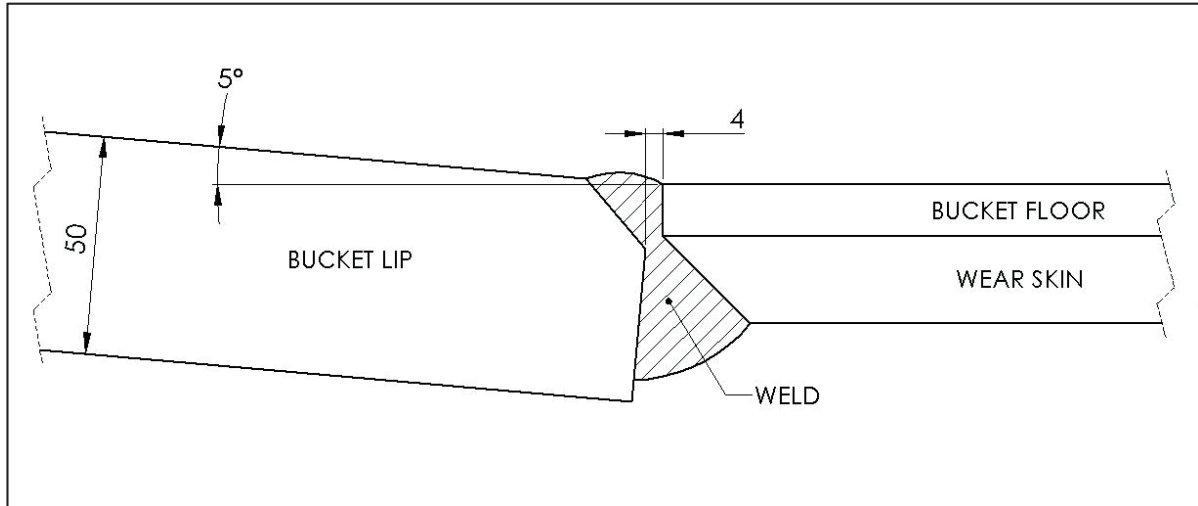

Lip Profile And Boss Set Back

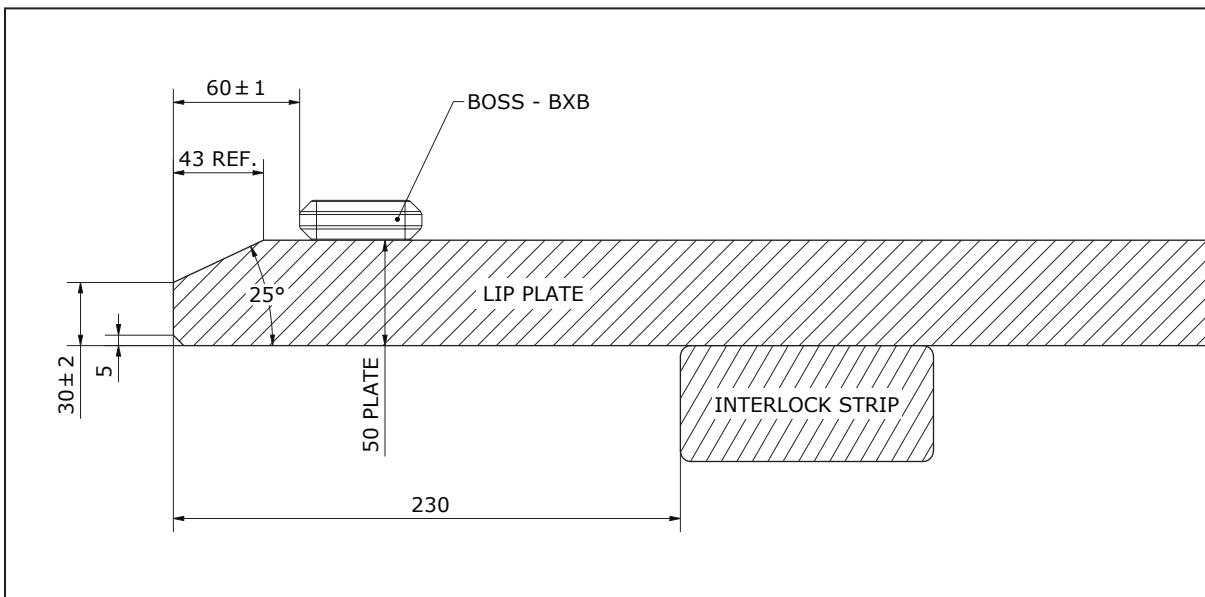

Lip profile must be relatively smooth and free of debris, such as weld spatter, metal deformation, cutting dags or other irregularities

Tolerances

Lip Thickness	Standard Lip Plate Tolerance
Leading Edge	± 2mm
Ramp Angle	+ 0 deg / -2 deg
Boss Set Back	± 1mm